



**Specification for Type ST Plug-in Relay  
Neutral Relay, Regular Release  
6FB Contacts, 900 Ohm**

Characteristic		Original Requirements	Contact/Coil Arrangement	
Coils	Nominal V or I	10-12 VDC	<p>(Front of Relay)</p>	
	Resistance/Tolerance	450 Ohm ±5% Each Coil		
Temperature Range		-40C (-40F) to 85C (185F)		
P.U./W.C.	Voltage	7.56 Volts Maximum		
	Current	8.4 milliamps Maximum		
	Speed	Pickup		Regular
Dropaway	Voltage	3.6 Volts Minimum		
	Current	4 milliamps Minimum		
	Speed	Release		Regular
Contacts	Arrangement	6FB		<p>Relay register (Rear of Relay)</p>
	Rating	4 Amps/30 Volts		
	Material	N.O.	Silver/Carbon	
		N.C.	Silver/Silver	
	Dynamic Gap		.020" Minimum	
	Contact Gap		.050" Minimum	
	Pressure	N.O.	40 Grams Minimum	
		N.C.	21 Grams Minimum	
	Overtravel per Adjustment A		*See Note #1 Below	
	Resistance	N.O.	90 milliohms Maximum @10 VDC, 1.0 Amps	
N.C.		30 milliohms Maximum @10 VDC, 1.0 Amps		
Armature Travel		.087" Minimum		
Retainer Gap Reference		.002" to .004"		
Residual Screw (Adjustable)		.010" Minimum		
Stop Pin (Fixed)		.008" Minimum		

**Notes**

- #1 N.O. Contacts to make with .032" and break with .041" between armature residual screw and core.
- N.C. Contacts to make with .066" and break with .059" between armature residual screw and core.

**Field Requirements**

- Drop Away Value — Not less than 70% of original marking.
- Pickup/Working Value — Not greater than 110% of original marking.

**Shop Requirements**

- Drop Away Value — Not less than 95% of original marking.
- Pickup/Working Value — Not greater than 105% of original marking.

# Type ST Plug-in Relay Assembly and Replacement Parts Part Number 400017

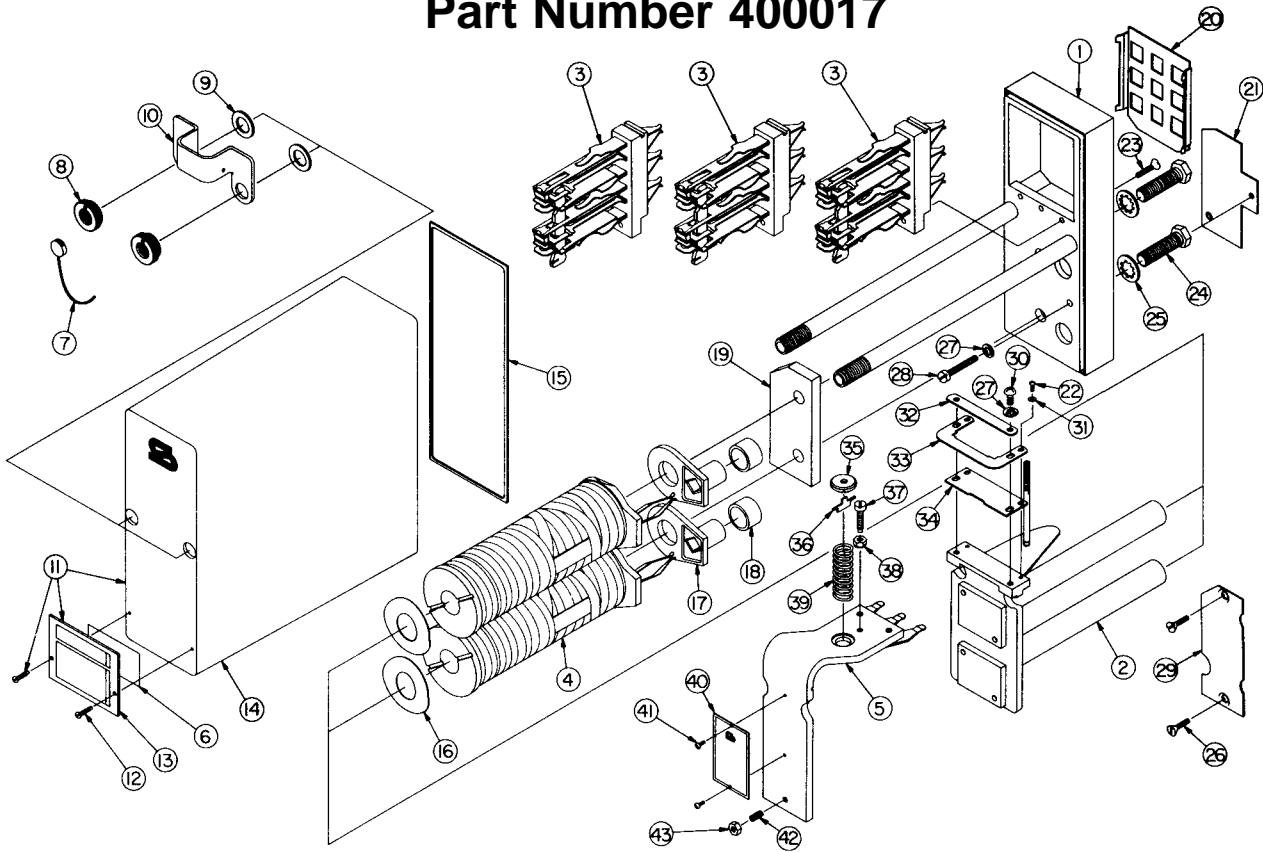

**To order, specify description and part number.**

Item No.	Description	Qty. Req'd.	Part Number	Item No.	Description	Qty. Req'd.	Part Number
1	Base Assembly, Plug-in Relay	1	420050-X	23	Machine Screw, Flat Head, #6-32 X .531"	3	420050-36
2	Frame Assembly, Coil	1	420053-X	24	Machine Screw, Hex Head, 5/16"-24 X 1.125"	2	420053-12
3	Stack, 2FB Contact	3	420052-1X	25	Washer, Spring Lock, I, 5/16"	2	420053-13
4	Coil Assembly, 450 Ohm	2	420051-4X	26	Machine Screw, Flat Head, #6-32 X .5"	2	420050-36
5	Armature	1	420053-1X	27	Washer, Spring Lock, I, #8	3	420050-33
6	Label, Paper Identification	1	420050-3	28	Machine Screw, Fillister Head, #8-32 X .937"	1	420050-32
7	Seal, Lead	1	420050-8	29	Plate, Code Pin	1	420050-39X
8	Nut, Knurl, Locking	2	420050-5	30	Machine Screw, Pan Head, #8-32 x .375"	2	420053-16
9	Washer, Flat Rubber	2	420050-7	31	Washer, Spring Lock, I, #4	2	420053-15
10	Bracket, Cover	1	420050-4	32	Plate, Retainer	1	420053-3
11	Cover Assembly	1	420050-2X	33	Retainer, Armature	1	420053-2
12	Tap Screw, Round Head, #4 X .375"	2	420050-35	34	Plate, Hinge	1	420053-1
13	Cover, Nameplate	1	420050-2	35	Nut, Spring Post	1	420053-6
14	Molded Cover, Clear	1	420050	36	Key, Spring Retainer	1	420053-5
15	Gasket, Cover	1	420050-1	37	Screw, Tailstop	1	420053-9
16	Washer, Spring	2	420053-7	38	Nut, Tailstop	1	420053-8
17	Insulator, Terminal Retainer	2	420051	39	Spring, Compression	1	420053-4
18	Seal, Rubber	2	420051-1	40	Nameplate, Type ST Relay	1	420053-19
19	Plate, Base	1	420053	41	Phillips Screw, Pan Head, #4-40 X .187"	2	420053-18
20	Seal, Dust	1	420052	42	Screw, Residual	1	420053-11
21	Plate, Code	1	420050-9	43	Nut, Residual	1	420053-10
22	Machine Screw, Fillister Head, #4-40 X .250"	2	420053-14				

**Safetran Systems Corporation**  
2400 Nelson Miller Parkway  
Louisville, Kentucky 40223  
502-244-7400